

Ångermanland



General

Built	1989
Length over all	104,85 m
Breadth moulded	16,26 m
max. draught	5,83 m
max. DWAT	4.334 mt
Speed	12,5 knots
GT	3.845 London Rules
NT	2.013 London Rules

Cargohold

Hatch / Hold	1 / 1
	Hydraulic operated folding covers
Bale	230.000 cbft

Class

Germanischer Lloyd 100 A 4, E 3, + MC, E 3, AUT strengthened for heavy cargo "G" equipped for carriage of container Ice class E 3, according Finnish Class 1 A

Cranes

2x 25 mt min / max. outreach 2,70 m - 21,0 m (portside)

Engine

Fuel Specification	IFO 180 cst according ISO 8217
Main Engine	1 x MaK, Kiel, type "8 M 453 C", 2.940 kW, qualified for heavy fuel oil IFO 180
Auxiliary Engine	3 x Zepp./Caterpillar, type "3406 DI-TAU", each 257 kW, qualified for gasoil

Cargo / Container Capacity

Container intake	320 TEU
Container intake	
14 mt homogeneous	217 TEU
in hold	20' TEU
total in hold	140
on deck	
total on deck	180
total hold and deck	320

Container Pointload

on tanktop	10 mt / m ³
------------	------------------------

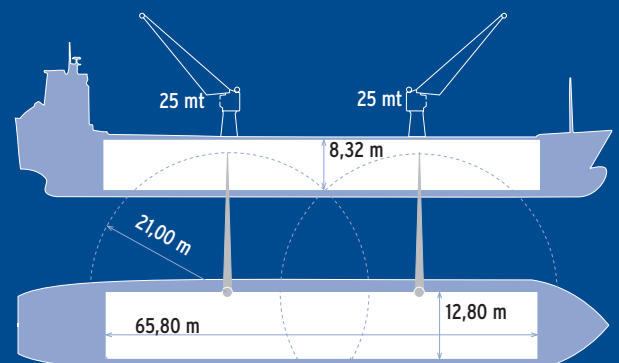

all details about and not to be used for charter parties